

First Name: _____ Last Name: _____

Problem 1 (20 Points)

- Mark all single stuck faults on Figure 1, taking one fault from each equivalence class.
- Use the Boolean difference to determine all possible tests for the fault “primary input A stuck-at-1”.
- Use the D-algorithm to obtain a test pattern T that detects the fault “line α stuck-at-1” in the logic circuit

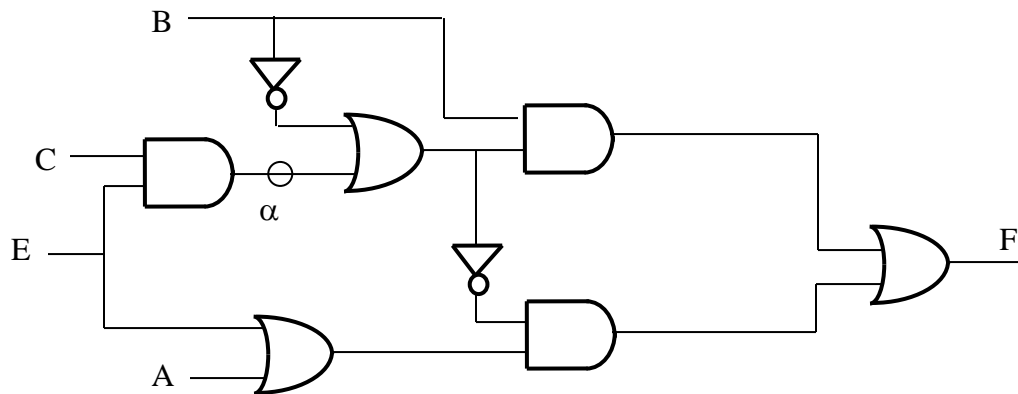

Figure 1

Problem 5 (15 Points)

Consider Figure 3 in which 4 processes (p, q, r, and s) execute concurrently and exchange information by message passing.

- Consider the following global states
 - $GS_1 = \{LS_{p1}, LS_{q1}, LS_{r1}, LS_{s1}\}$
 - $GS_2 = \{LS_{p2}, LS_{q2}, LS_{r2}, LS_{s2}\}$
 - $GS_3 = \{LS_{p3}, LS_{q3}, LS_{r3}, LS_{s3}\}$
 - $GS_4 = \{LS_{p4}, LS_{q4}, LS_{r4}, LS_{s4}\}$

Discuss whether each of the indicated global state is a consistent or inconsistent global state.

- Construct a dependency graph and determine the recovery line for the indicated faults.

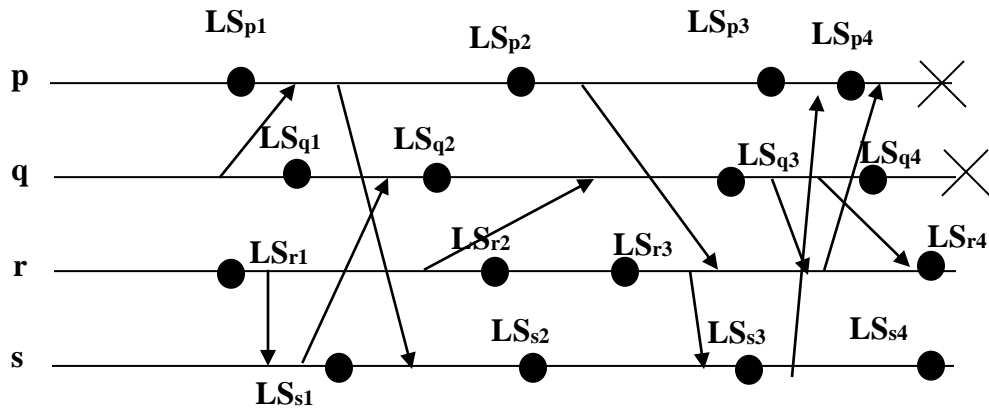

Figure 2

Problem 6 (25 Points)

Consider Figure 3 in which 4 processes (P_0, P_1, P_2, P_3) execute concurrently and exchange information by message passing.

a. Consider the following global states

I. $GS_1 = \{C_{0,0}, C_{1,0}, C_{2,0}, C_{3,0}\}$

II. $GS_2 = \{C_{0,1}, C_{1,1}, C_{2,1}, C_{3,1}\}$

III. $GS_3 = \{C_{0,2}, C_{1,2}, C_{2,2}, C_{3,2}\}$

IV. $GS_4 = \{C_{0,3}, C_{1,3}, C_{2,3}, C_{3,3}\}$

Discuss whether each of the indicated global state is a consistent or inconsistent global state.

b. Construct a dependency graph and determine the recovery line for the indicated faults.

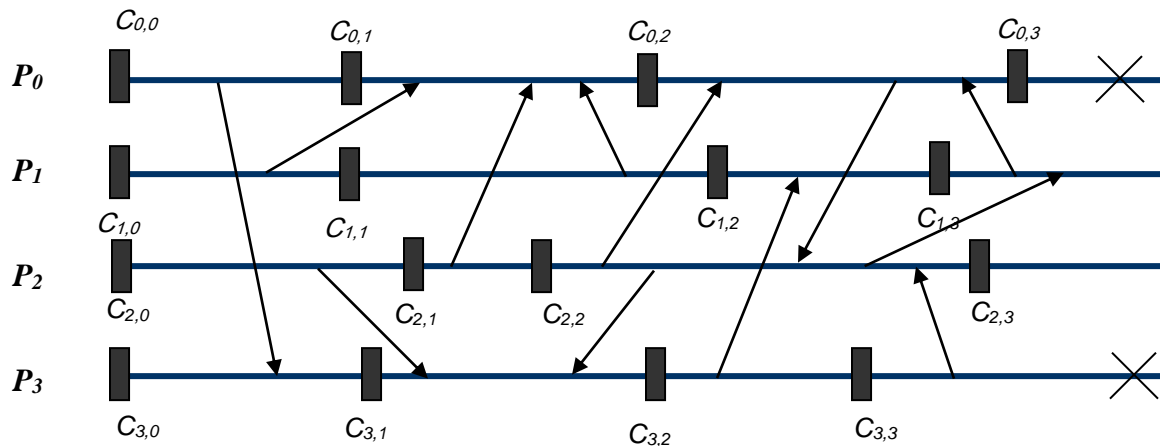

Figure 3