

Name: _____

Problem 1 (20 Points)

- Mark all single stuck faults on Figure 1 below, taking one fault from each equivalence class.
- Use the Boolean difference to determine all possible tests for the fault “primary input A stuck-at-0”.
- Use the D-algorithm to obtain a test pattern T that detects the fault “line α stuck-at-0” in the logic circuit

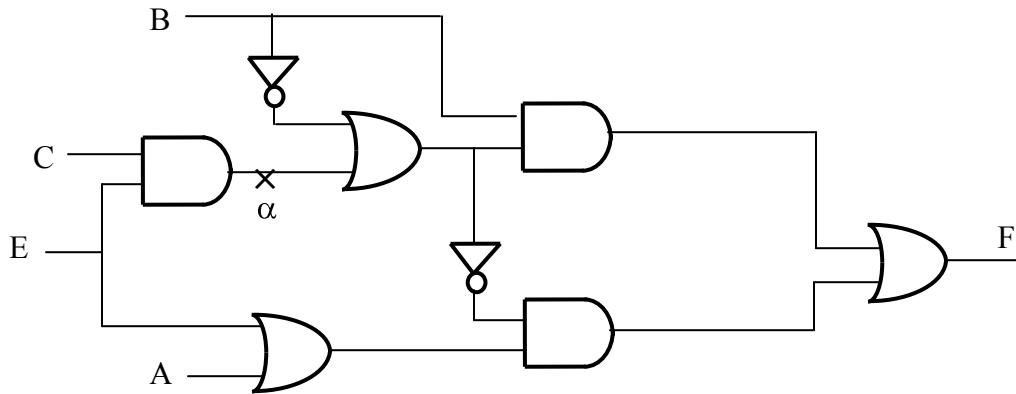

Figure 1

Problem 2 (20 Point)

- Mark all single stuck faults on Figure 2, taking one fault from each equivalence class.
- Use the Boolean difference to determine all possible tests for the fault “primary input A stuck-at-0”.
- Use the D-algorithm to obtain a test pattern T that detects the fault “line α stuck-at-1” in the logic circuit

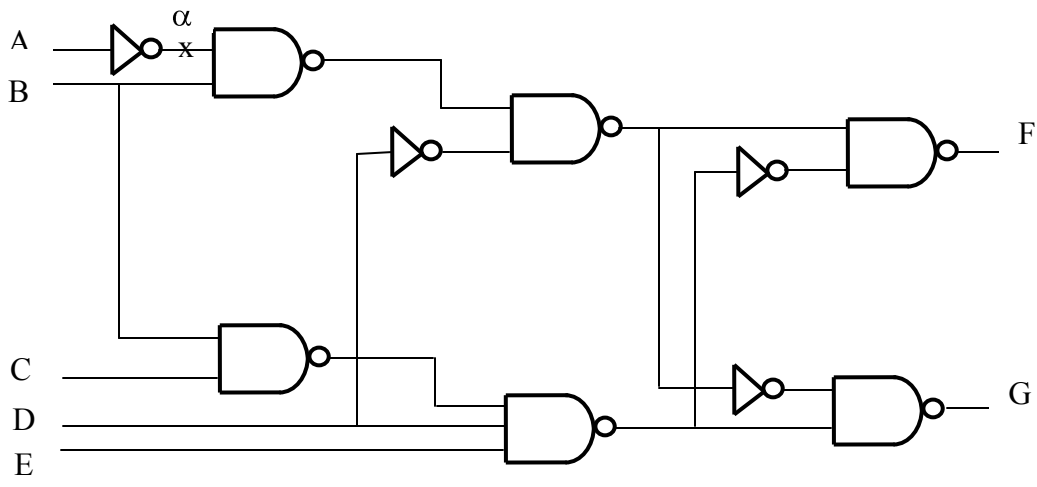

Figure 2

Problem 3 (20 Points)

Consider Figure 3 in which 4 processes (p, q, r, and s) execute concurrently and exchange information by message passing. Consider the following global states

- I. $GS_1 = \{LS_{p1}, LS_{q1}, LS_{r1}, LS_{s1}\}$
- II. $GS_2 = \{LS_{p2}, LS_{q2}, LS_{r2}, LS_{s2}\}$
- III. $GS_3 = \{LS_{p3}, LS_{q3}, LS_{r3}, LS_{s3}\}$
- IV. $GS_4 = \{LS_{p4}, LS_{q4}, LS_{r4}, LS_{s4}\}$

Discuss whether each of the indicated global state is a consistent or inconsistent global state.

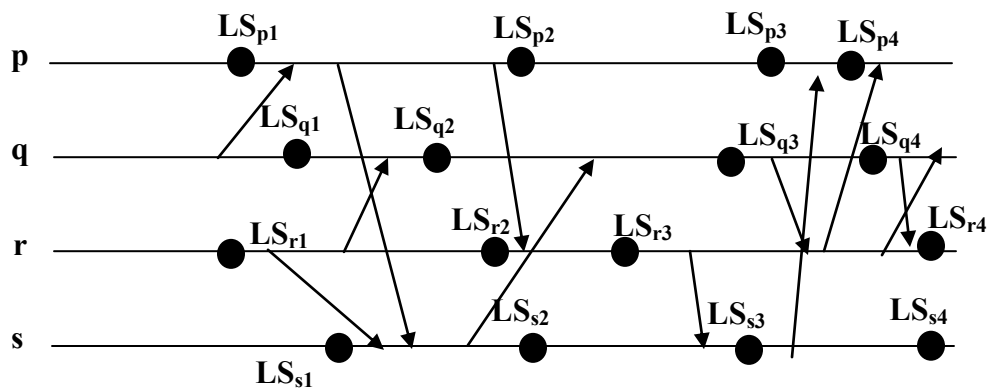

Figure 3